



NetOrder 3.0.0  
API Reference Rev. 1.01(Draft)

Noritsu Koki Co., Ltd.

Table of contents

<b><u>1.</u></b>	<b><u>Revision History</u></b> .....	<b>3</b>
<b><u>2.</u></b>	<b><u>Scope</u></b> .....	<b>3</b>
<b><u>3.</u></b>	<b><u>Overview</u></b> .....	<b>3</b>
3.1.	<u>Sheet Paper Support</u> .....	3
3.2.	<u>Duplex Printing</u> .....	3
<b><u>4.</u></b>	<b><u>Term</u></b> .....	<b>3</b>
<b><u>5.</u></b>	<b><u>Structure</u></b> .....	<b>4</b>
<b><u>6.</u></b>	<b><u>API</u></b> .....	<b>4</b>
<b><u>7.</u></b>	<b><u>Sequence</u></b> .....	<b>5</b>
<b><u>8.</u></b>	<b><u>Reference</u></b> .....	<b>5</b>
8.1.	<u>QSS_PRINTER_INFO(WSQSS_PRINTER_INFO)</u> .....	8
8.2.	<u>QSS_PAPER_INFO_AD(WSQSS_PAPER_INFO_AD)</u> .....	9
8.3.	<u>QSS_FRAME_PARAM_AD</u> .....	11
8.4.	<u>QSS_ORDER_PARAM_AD(WSQSS_ORDER_PARAM_AD)</u> .....	15
8.5.	<u>QSSGETPRINTERINFO</u> .....	22
8.6.	<u>QSSGETPAPERAD</u> .....	22
8.6.1.	<u>Command for TCP/IP</u> .....	23
8.6.2.	<u>Return Value</u> .....	23
8.6.3.	<u>Description</u> .....	24
8.7.	<u>QSSTRANSMITFILEAD</u> .....	24
8.7.1.	<u>Command Format for TCP/IP</u> .....	24
8.7.2.	<u>Return Value</u> .....	25
8.8.	<u>QSSSETORDERAD</u> .....	25
8.8.1.	<u>Command Format for TCP/IP</u> .....	25
8.8.2.	<u>Return Value</u> .....	26
8.8.3.	<u>Description</u> .....	26
8.9.	<u>QSSSETBLANKPAGEAD</u> .....	26
8.9.1.	<u>Command for TCP/IP</u> .....	26
8.9.2.	<u>Return Value</u> .....	27
8.9.3.	<u>Description</u> .....	27
<b><u>9.</u></b>	<b><u>Note to Use the Advanced Functions</u></b> .....	<b>30</b>
9.1.	<u>Printing on the Sheet Paper</u> .....	30
9.2.	<u>Duplex Printing</u> .....	31

## 1. Revision History

<i>Date</i>	<i>Description</i>	<i>Revision</i>
Nov 5, 2008	Newly created	1.00
Dec 25, 2008	Description of the following variables were added: QSS_ORDER_PARAM_AD ::PaperLengthMin QSS_ORDER_PARAM_AD ::PaperLengthMax QSS_ORDER_PARAM_AD ::PaperLengthMinB QSS_ORDER_PARAM_AD ::PaperLengthMaxB QSS_ORDER_PARAM_AD ::PaperLengthMinC QSS_ORDER_PARAM_AD ::PaperLengthMaxC QSS_ORDER_PARAM_AD ::PaperLengthMinD QSS_ORDER_PARAM_AD ::PaperLengthMaxD	1.01

## 2. Scope

This document explains NetOrder 3.0.0 that has been added to EZ Controller. Supported OS are Windows 2000, XP (x32), Vista (x32), XP (x64) and Vista (x64). NetOrder 3.0.0 is available for 32- and 64-bit native applications. Overview

NetOrder 3.0.0 provides applications with the functions to print on the material such as postcard, greeting card and photo book on the dry minilabs that support sheet paper and duplex printing . This document explains how to use the functions newly added to NetOrder 3.0.0 from the application. NetOrder SDK 3.0.0 is required to make these new functions available with the application.

Added functions are as follows:

- Sheet paper support
- Duplex printing
- Resolution change
- Collation

### 2.1. Sheet Paper Support

Printing on the sheet paper is available. Note that this function is available only with the dry minilab that supports sheet paper.

### 2.2. Duplex Printing

Duplex printing on the sheet paper is available with the dry minilabs that are capable of duplex printing.

### 2.3. Resolution change

It is possible to change resolution and gradation for printing with respect to each paper type.

### 2.4. Collation

When making multiple copies of photos and/or photobooks, they can be collated for each group, which will make it easier to make photobooks and to sort prints.

Collation:

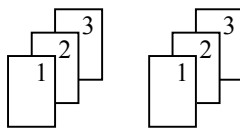

### 3. Term

Dry minilab	Inkjet type minilab (e.g. M300, D701)
Fast print	When printer is ready for printing, it will not wait for the entire order to be received but start printing as soon as it finishes receiving each image within an order.

### 4. Structure

Structure	Structure for TCP/IP	Description
QSS_PRINTER_INFO	WSQSS_PRINTER_INFO	Store the information unique to NetOrder and the printer.
QSS_PAPER_INFO_AD	WSQSS_PAPER_INFO_AD	Store the information of available paper.
QSS_FRAME_PARAM_AD	WSQSS_FRAME_PARAM_AD	Store the image information.
QSS_ORDER_PARAM_AD	WSQSS_ORDER_PARAM_AD	Store the order information.

### 5. API

API	Command ID for TCP/IP		Description	Remarks
QssGetName	Request	0100H	Get the information that is unique to NetOrder and the printer from the printer.	
	Response	0110H		
QssGetPaperAD	Request	2100H	Get the information of the available paper from the printer.	Newly added API
	Response	2101H		
QssTrasmitFileAD	Request	2200H	Send the image data to the printer.	Newly added API
	Response	2201H		
QssSetOrderAD	Request	2300H	Send the order to the printer.	Newly added API
	Response	2301H		
QssSetBlankPageAD	Request	2400H	Insert a blank page. To be used to insert a blank page for photo book printing.	Newly added API
	Response	2401H		

## 6. Sequence

Call the API when QSS\_PRINTER\_INFO ::EnableExtension of QssGetName() is QSS\_TRUE.

- When the fast print function is not used:

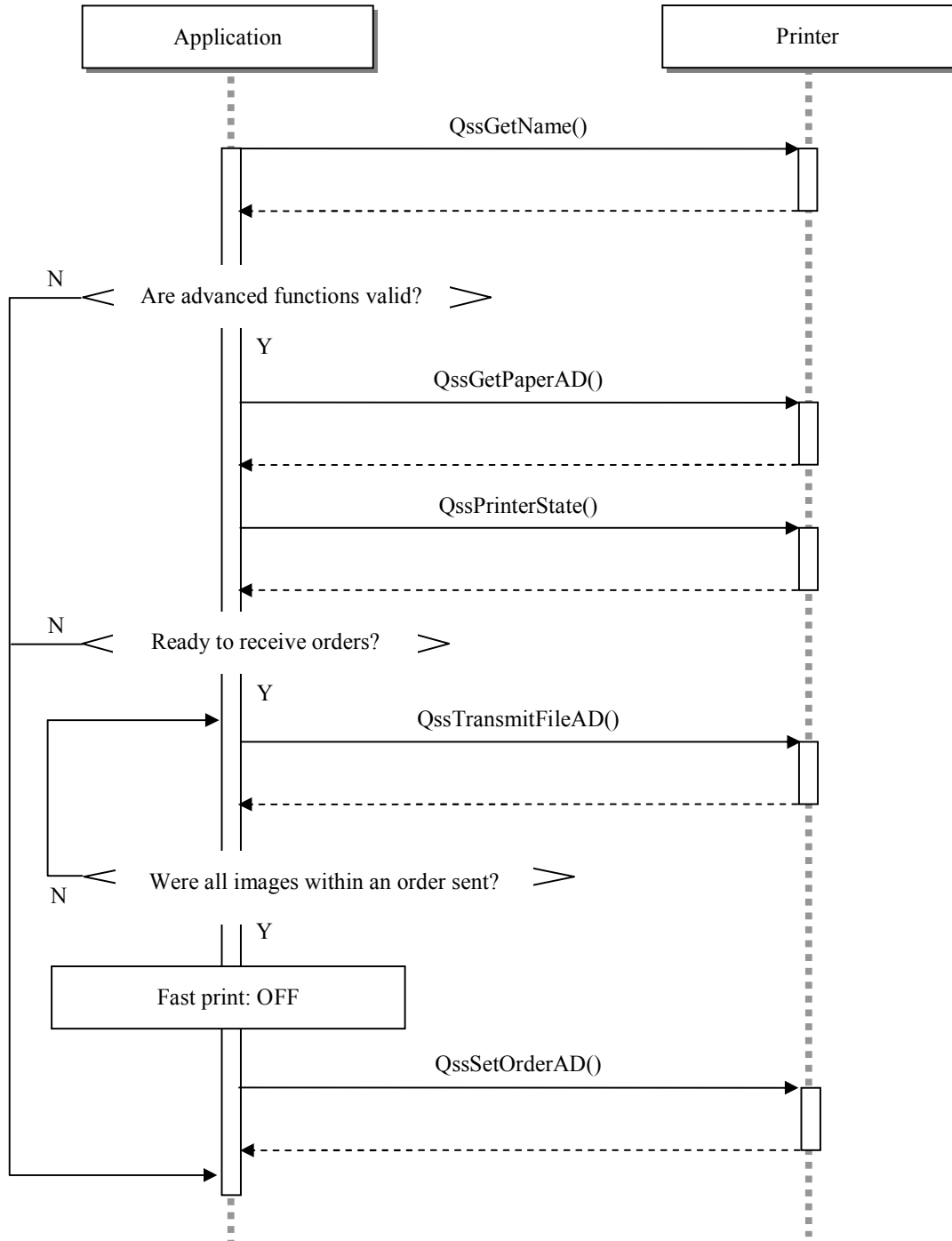

- When the fast print function is used:

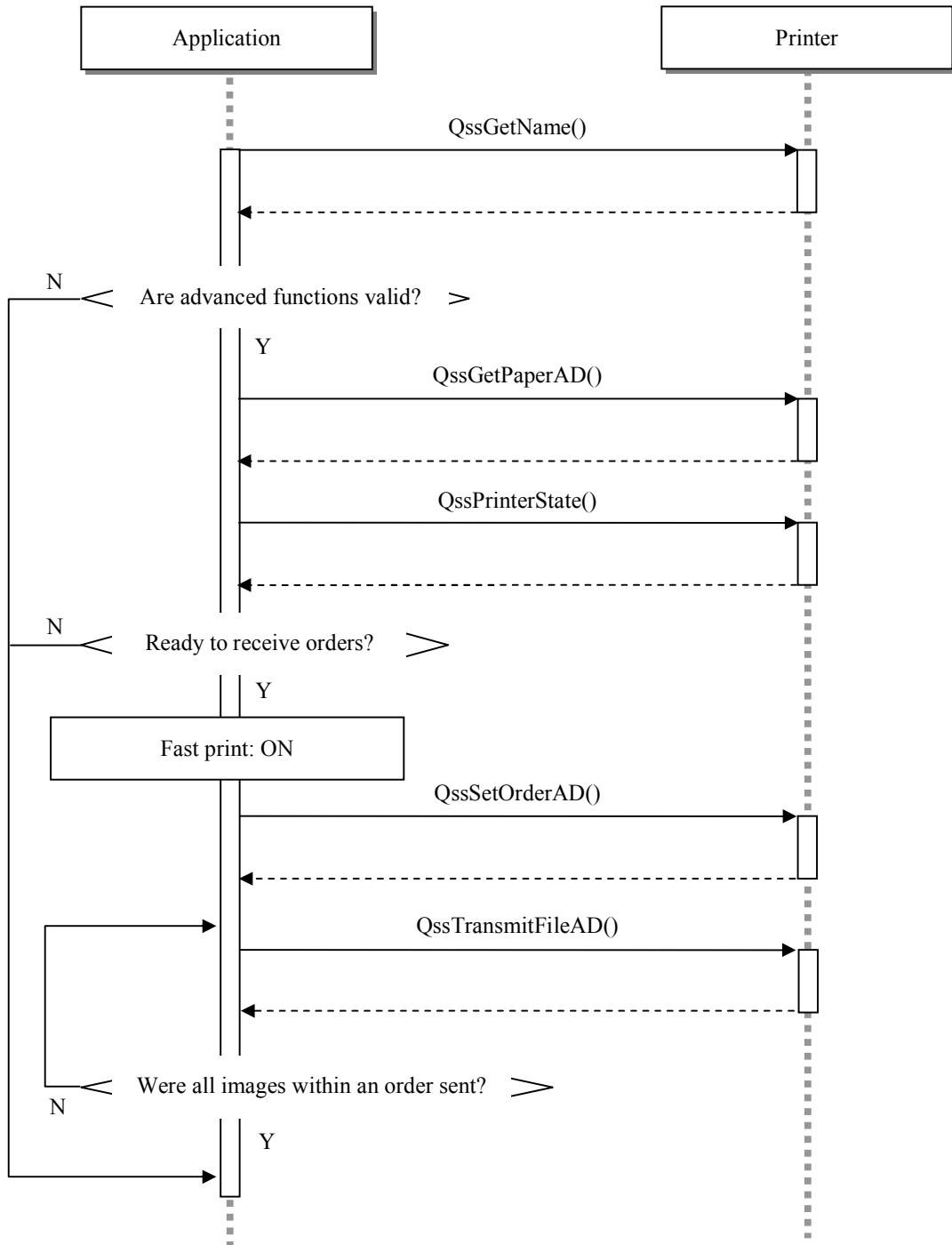

## 7. Reference

### 7.1. QSS\_PRINTER\_INFO(WSQSS\_PRINTER\_INFO)

```
typedef struct _QSS_PRINTER_INFO {
    char          Name[20];
    unsigned long Version;
    unsigned char IPAddress[4];
    unsigned short SystemInfo;
    unsigned short EnableExtension; **
    unsigned short EnableBothSidePrint; **
    unsigned char Reserve[30];
} QSS_PRINTER_INFO;
```

[For TCP/IP]

```
typedef struct _WSQSS_PRINTER_INFO {
    unsigned char Name[20];
    unsigned long Version;
    unsigned char IPAddress[4];
    unsigned short SystemInfo;
    unsigned short EnableExtension; **
    unsigned short EnableBothSidePrint; **
    unsigned char Reserve[30];
} WSQSS_PRINTER_INFO;
```

\*\* shows the difference from ver. 2.3.0.

Name [out]

Model name of the printer. The string is NULL terminated.

Version [out]

Version of NetOrder. The version is set in hexadecimal.

If the version is 3.0.0.0, 0x03000000 is set.

IPAddress [out]

IP address of the printer

SystemInfo [out]

Unused

EnableExtension [out]

Specify whether the advanced functions are valid. Advanced functions are available when valid.

QSS_TRUE	1	Valid. Advanced API's such as QssSetOrderAD() are available.
QSS_FALSE	0	Invalid

EnableBothSidePrint

Specify whether duplex printing is valid. Duplex printing is available when valid. You can check whether the printer supports duplex printing with this variable.

QSS_TRUE	1	Valid. Duplex printing is available.
QSS_FALSE	0	Invalid

Reserve

Unused

### 7.2. QSS\_PAPER\_INFO\_AD(WSQSS\_PAPER\_INFO\_AD)

```
typedef struct _QSS_PAPER_INFO_AD {
    unsigned short PaperWidth;
    unsigned short Resolut;
    unsigned short MagazineState;
    unsigned long PaperRemaind;
    unsigned short Surface;
    unsigned short PaperLengthMin;
```

```

    unsigned short PaperLengthMax;
    unsigned short PaperSource; **
    char PaperName[32]; **
    unsigned short Borderless; **
    short TrimTop; **
    short TrimBottom; **
    short TrimLeft; **
    short TrimRight; **
    unsigned short PaperTone; **
    unsigned char Reserve[38];
} QSS_PAPER_INFO_AD;

```

[For TCP/IP]

```

typedef struct _WSQSS_PAPER_INFO_AD {
    unsigned short PaperWidth;
    unsigned short Resolut;
    unsigned short MagazineState;
    unsigned long PaperRemaind;
    unsigned short Surface;
    unsigned short PaperLengthMin;
    unsigned short PaperLengthMax;
    unsigned short PaperSource; **
    char PaperName[32]; **
    unsigned short Borderless; **
    short TrimTop; **
    short TrimBottom; **
    short TrimLeft; **
    short TrimRight; **
    unsigned short PaperTone; **
    unsigned char Reserve[38];
} WSQSS_PAPER_INFO_AD;

```

\*\* shows differences from QSS\_PAPER\_INFO or WSQSS\_PAPER\_INFO.

PaperWidth [out]

Paper width (unit: 1/10 mm)

Resolut [out]

Default printing resolution (unit: 1/10 dpi)

When different printing resolutions are designated for paper with the same paper width and the same paper surface, the paper will be treated as 2 different types of paper.

MagazineState [out]

Location of the magazine installed. Refer to "NetOrder 2.3.0 API Reference".

PaperRemaind [out]

The length of the remaining paper in the paper magazine (unit: 1/10 mm)

When it is QSS\_MAGAZINE\_TAKEUP, it specifies the length of paper that is taken up.

In case of the sheet paper, 0 is set.

Surface [out]

Paper surface number (range: 1 to 4)

PaperLengthMin [out]

PaperLengthMax [out]

Available range of the paper advance length (unit: 1/10 mm)

PaperLengthMin is minimum possible advance length and PaperLengthMax is maximum possible advance length.

In case of the sheet paper, the height of the resultant paper is specified for both PaperLengthMin and PaperLengthMax. With the dry minilab, the top and bottom of the paper will be cut while printing. The size that the length to be cut from the paper is excluded is specified for this variable.

PaperSource [out]



Type of paper source. The paper type to be supplied is specified.

QSS_PAPERSOURCE_ROLL	0	Roll paper
QSS_PAPERSOURCE_SHEET	1	Sheet paper

PaperName [out]

Paper name (32 byte)

The string is NULL terminated. In case of the roll paper, paper name is not specified.

Borderless [out]

Specify the presence of white border. In case of the roll paper, the resultant print will be always borderless.

QSS_TRUE	Borderless
QSS_FALSE	With border

TrimTop [out]

TrimBottom [out]

TrimLeft [out]

TrimRight [out]

Amount of cropping (unit: 1/10 mm)

Actual print area will differ depending on the paper type or the presence of the border even with the same paper size. When the application creates the print image of the real size, the image needs to be cropped so the image matches the print area. This variable specifies the amount of cropping, and is specified with positive value for borderless paper and with negative value for paper with border.

PaperTone [out]

Gradation

Color depth for a pixel is set as a bit value to represent the gradation of paper. To confirm which bit value is set, apply logical AND operator (&) for each bit.

QSS_PAPER_TONE_24	0 bit	24 bpp
QSS_PAPER_TONE_36	1 bit	36 bpp
QSS_PAPER_TONE_48	2 bit	48 bpp

Reserve

Unused

### 7.3. QSS\_FRAME\_PARAM\_AD(WSQSS\_FRAME\_PARAM\_AD)

```
typedef struct _QSS_FRAME_PARAM_AD {
    unsigned short OrderNo;
    unsigned short FrameNum;
    unsigned short FrameNo;
    char FileName[18];
    unsigned long  FileSize;
    unsigned long  ImageFormat;
    unsigned short PrintSize;
    unsigned short RepeatNum;
    unsigned short RepeatPos;
    char CvpString1[120];
    char CvpString2[120];
    unsigned short CvpFlg;
    unsigned short PaperWidth;
    unsigned short PaperLength;
    unsigned short Surface;
    unsigned short WithBorder;
    unsigned short PaperFittingFlg;
    unsigned short ImageXPixels;
    unsigned short ImageYPixels;
    unsigned short Reserve1;
    unsigned hyper RefId;
    unsigned short SizeRate;
    unsigned short Rotate;
}
```

```

short      CenterX;
short      CenterY;
char       Reserve2[8];
char       PaperName[32]; **
unsigned short Resolut; **
unsigned short PaperTone; **
unsigned short TrimStartPointX; **
unsigned short TrimStartPointY; **
unsigned short TrimSizeX; **
unsigned short TrimSizeY; **
unsigned short TrimUnitSize; **
unsigned short EnablePaperFittingFlg; **
char       FrontPrintString[32]; **
unsigned short FrontPrintFlg; **
unsigned char Reserve[78];
} QSS_FRAME_PARAM_AD;

```

[For TCP/IP]

```

typedef struct _WSQSS_FRAME_PARAM_AD {
    unsigned short OrderNo;
    unsigned short FrameNum;
    unsigned short FrameNo;
    char          FileName[18];
    unsigned long  FileSize;
    unsigned long  ImageFormat;
    unsigned short PrintSize;
    unsigned short RepeatNum;
    unsigned short RepeatPos;
    char          CvpString1[120];
    char          CvpString2[120];
    unsigned short CvpFlg;
    unsigned short PaperWidth;
    unsigned short PaperLength;
    unsigned short Surface;
    unsigned short WithBorder;
    unsigned short PaperFittingFlg;
    unsigned short ImageXPixels;
    unsigned short ImageYPixels;
    unsigned short Reserve1;
    unsigned hyper RefId;
    unsigned short SizeRate;
    unsigned short Rotate;
    short          CenterX;
    short          CenterY;
    unsigned char  Reserve2[8];
    char          PaperName[32]; **
    unsigned short Resolut; **
    unsigned short PaperTone; **
    unsigned short TrimStartPointX; **
    unsigned short TrimStartPointY; **
    unsigned short TrimSizeX; **
    unsigned short TrimSizeY; **
    unsigned short TrimUnitSize; **
    unsigned short EnablePaperFittingFlg; **
    char          FrontPrintString[32]; **
    unsigned short FrontPrintFlg; **
    unsigned char  Reserve[78];
}

```

} WSQSS\_FRAME\_PARAM\_AD;

\*\* shows differences from QSS\_FRAME\_PARAM and QSS\_FRAME\_PARAM2.

OrderNo [in]

Request number. Specify any number (range: 1 to 65535)  
When 65535 (0xFFFF) is specified, RefId becomes valid.

FrameNum [in]

Number of the image. Specify the number of the image included in the order (range: 1 to 9999).

FrameNo [in]

Frame number (range: 1~999)

FileName [in]

Name of the image file (17 byte)  
The string is NULL terminated.

FileSize [in]

File size (unit: byte)  
Specify the file size of the image to be sent to the printer.

ImageFormat [in]

Image format. Specify the format of the image to be sent to the printer.

QSS_FORMAT_JPEG	JPEG
QSS_FORMAT_BMP	BMP
QSS_FORMAT_TIFF	TIFF
QSS_FORMAT_PHOTOSHOP	PSD

Supported format will differ depending on the printer. You can check which format is supported with SupportImageFormat of QSS\_PRINTER\_STATE of QssGetPrinterState().

PrintSize [in]

Print size. When duplex printing is specified, this variable will be ignored.

QSS_PRINT_SIZE_C	The values of PaperWidth, PaperLengthC, Surface and WithBorderC of QSS_ORDER_PARAM_AD are applied.
QSS_PRINT_SIZE_P	The values of PaperWidth, PaperLengthP, Surface and WithBorderP of QSS_ORDER_PARAM_AD are applied.
QSS_PRINT_SIZE_H	The values of PaperWidth, PaperLengthH, Surface and WithBorderH of QSS_ORDER_PARAM_AD are applied.
QSS_PRINT_SIZE_FREE_C	The values of PaperWidth, PaperLength and Surface of QSS_FRAME_PARAM_AD and that of WithBorderC of QSS_ORDER_PARAM_AD are applied.
QSS_PRINT_SIZE_FREE_P	The values of PaperWidth, PaperLength and Surface of QSS_FRAME_PARAM_AD and that of WithBorderP of QSS_ORDER_PARAM_AD are applied.
QSS_PRINT_SIZE_FREE_H	The values of PaperWidth, PaperLength and Surface of QSS_FRAME_PARAM_AD and that of WithBorderH of QSS_ORDER_PARAM_AD are applied.

RepeatNum [in]

Number of repeat print (range: 0 to 999)  
When duplex printing is specified, this variable will be ignored.

RepeatPos [in]

Position of repeat count printing. Specify the position to print the repeat count as CVP. When you do not want the repeat count to be printed, specify 255. With the dry minilab that supports duplex printing, this variable will be ignored.

CvpString1 [in]

CvpString2 [in]

CVP string. Specify the string to be printed as CVP. Specify the string to be printed on the 1<sup>st</sup> line of CVP printing in CvpString1, and that on the 2<sup>nd</sup> line in CvpString2. With the dry minilab that supports duplex printing, this variable will be ignored.

CvpFlg [in]

Specify whether the printer automatically creates the CVP string to use or uses the strings specified in CvpString1 and/or CvpString2. With the dry minilab that supports duplex printing, this variable will be ignored.

QSS_CVP_AUX	Use the strings specified in CvpString1 and CvpString2.
QSS_CVP_1QSS2AUX	Use the string specified in CvpString2.
QSS_CVP_1AUX2QSS	Use the string specified in CvpString1.
QSS_CVP_QSS	CvpString1 and CvpString2 not used.

PaperWidth [in]

Paper width (unit: 1/10 mm)

Specify the paper width to be printed.

PaperLength [in]

Paper advance length (height) (unit: 1/10 mm)

Specify the advance length/height of the paper to be printed. You can check the available range with QssGetPaperAD(). In case of printing on the sheet paper, specify the value of QSS\_PAPER\_INFO\_AD::PaperLengthMin of QssGetPaperAD ().

WithBorder [in]

Specify the width of border. (range: 0-99, unit: 1/10 mm)

To print a print with border on sheet paper, specify borderless paper. Otherwise, the resulting border will not be of the intended width. When this variable is set to 0,

QSS\_ORDER\_PARAM\_AD::WithBorder (border width of order information) will be used.

PaperFittingFlg [in]

Paper fitting. Specify the size of the image to be printed.

When QSS\_FRAME\_PARAM\_AD::EnablePaperFittingFlg (paper fitting flag) is 0, this variable will be ignored, and QSS\_FRAME\_PARAM\_AD::PaperFittingFlg (paper fitting of order information) will be used.

QSS_PF_CUT	Cut (Crop) Size of image will be adjusted so that the resulting print will not include any border in it. In case the aspect ratio of image and of page is different, some part of image may not appear on the resulting print.
QSS_PF_WHOLE	Overall (Shrink) Size of image will be adjusted so that the entire image will appear on the resulting print. In case the aspect ratio of image and page is different, white border may appear on the end of the resulting print.
QSS_PF_SAME	Real (Real size) Original size of the image will be maintained with no resizing.

ImageXPixels [in]

Unused

ImageYPixels [in]

Unused

Reserve1

Unused

RefId [in]

Reference number. Specify any number. When the number exceeds 65535, RefId is used (range: 1 to 999999999999999999).

SizeRate [in]

Unused

Rotate [in]

Unused

CenterX [in]

Unused

CenterY [in]

Unused

- PaperName [in]  
 Paper name (32 byte)  
 The string is NULL terminated. In case of printing on the sheet paper, specify the paper name of the paper information (QSS\_PAPER\_INFO\_AD). In case of printing on the roll paper, specify NULL.
- Resolut [in]  
 Resolution (unit: 1/10 dpi)  
 Specify the resolution of paper to use for printing. When 0 is set in this variable, the default resolution of the paper will be used.
- PaperTone [in]  
 Gradation  
 Color depth for a pixel is specified to represent the gradation of paper.  
 In case QSS\_PAPER\_TONE\_NONE is set, gradation specified on the printer will be used.
- |                     |             |
|---------------------|-------------|
| QSS_PAPER_TONE_NONE | Not specify |
| QSS_PAPER_TONE_24   | 24 bpp      |
| QSS_PAPER_TONE_36   | 36 bpp      |
| QSS_PAPER_TONE_48   | 48 bpp      |
- TrimStartPointX [in]  
 Unused
- TrimStartPointY [in]  
 Unused
- TrimSizeX [in]  
 Unused
- TrimSizeY [in]  
 Unused
- TrimUnitSize [in]  
 Unused
- EnablePaperFittingFlg [in]  
 Paper fitting flag  
 When paper fitting (QSS\_FRAME\_PARAM\_AD::PaperFittingFlg) is not to be used, set 0.  
 Otherwise set 1.
- FrontPrintString [in]  
 Text string for front print (32 byte)  
 Specify the text string for front print. Specify any Noritsu character code and NULL-terminate the string. You may set up to 31 characters, but the number of characters to be printed will vary depending on the type of printer and the advance length of the paper.  
 In case QSS\_FRAME\_PARAM\_AD::FrontPrintFlg (front print printing position) is set to "QSS\_FP\_NONE" (no front print), this variable will be ignored.
- FrontPrintFlg [in]  
 Unused
- Reserve  
 Unused

#### 7.4. QSS\_ORDER\_PARAM\_AD(WSQSS\_ORDER\_PARAM\_AD)

```
typedef struct _QSS_ORDER_PARAM_AD {
    unsigned short OrderNo;
    unsigned short FrameNum;
    unsigned short PaperWidth;
    unsigned short PaperLengthC;
    unsigned short PaperLengthP;
    unsigned short PaperLengthH;
    unsigned short Surface;
    unsigned short WithBorderC;
    unsigned short WithBorderP;
    unsigned short WithBorderH;
    unsigned short IndexPrintFlg;
}
```

```

unsigned short PaperFittingFlg;
unsigned short IndexPaperWidth;
unsigned short IndexSurface;
unsigned short CmsFlg;
unsigned short Reserve1;
unsigned hyper RefId;
unsigned short SorterNum;
char PaperName[32]; **
unsigned short BothSidePrint; **
unsigned short Copies; **
unsigned short Collate; **
unsigned short FastPrintFlg; **
unsigned short Resolut; **
unsigned short PaperTone; **
unsigned short PaperLengthMin; **
unsigned short PaperLengthMax; **
unsigned short PaperWidthB; **
unsigned short PaperSurfaceB; **
char PaperNameB[32]; **
unsigned short ResolutB; **
unsigned short PaperToneB; **
unsigned short PaperLengthMinB; **
unsigned short PaperLengthMaxB; **
unsigned short PaperWidthC; **
unsigned short PaperSurfaceC; **
char PaperNameC[32]; **
unsigned short ResolutC; **
unsigned short PaperToneC; **
unsigned short PaperLengthMinC; **
unsigned short PaperLengthMaxC; **
unsigned short PaperWidthD; **
unsigned short PaperSurfaceD; **
char PaperNameD[32]; **
unsigned short ResolutD; **
unsigned short PaperToneD; **
unsigned short PaperLengthMinD; **
unsigned short PaperLengthMaxD; **
unsigned short IndexPrintNum; **
unsigned short EnablePriority; **
unsigned short Priority; **
unsigned short PrintMode; **
unsigned short Wait; **
unsigned short BlankPageNum; **
unsigned char Reserve[6];
} QSS_ORDER_PARAM_AD;

```

```

[For TCP/IP]
typedef struct _WSQSS_ORDER_PARAM_AD {
    unsigned short OrderNo;
    unsigned short FrameNum;
    unsigned short PaperWidth;
    unsigned short PaperLengthC;
    unsigned short PaperLengthP;
    unsigned short PaperLengthH;
    unsigned short Surface;
    unsigned short WithBorderC;
    unsigned short WithBorderP;
}

```

```

unsigned short WithBorderH;
unsigned short IndexPrintFlg;
unsigned short PaperFittingFlg;
unsigned short IndexPaperWidth;
unsigned short IndexSurface;
unsigned short CmsFlg;
unsigned short Reserve1;
unsigned _int64 RefId;
unsigned short SorterNum;
char PaperName[32]; **
unsigned short BothSidePrint; **
unsigned short Copies; **
unsigned short Collate; **
unsigned short FastPrintFlg; **
unsigned short Resolut; **
unsigned short PaperTone; **
unsigned short PaperLengthMin; **
unsigned short PaperLengthMax; **
unsigned short PaperWidthB; **
unsigned short PaperSurfaceB; **
char PaperNameB[32]; **
unsigned short ResolutB; **
unsigned short PaperToneB; **
unsigned short PaperLengthMinB; **
unsigned short PaperLengthMaxB; **
unsigned short PaperWidthC; **
unsigned short PaperSurfaceC; **
char PaperNameC[32]; **
unsigned short ResolutC; **
unsigned short PaperToneC; **
unsigned short PaperLengthMinC; **
unsigned short PaperLengthMaxC; **
unsigned short PaperWidthD; **
unsigned short PaperSurfaceD; **
unsigned short PaperNameD[32]; **
unsigned short ResolutD; **
unsigned short PaperToneD; **
unsigned short PaperLengthMinD; **
unsigned short PaperLengthMaxD; **
unsigned short IndexPrintNum; **
unsigned short EnablePriority; **
unsigned short Priority; **
unsigned short PrintMode; **
unsigned short Wait; **
unsigned short BlankPageNum; **
unsigned char Reserve[6];
} WSQSS_ORDER_PARAM_AD;

```

\*\* shows differences from QSS\_ORDER\_PARAM and QSS\_ORDER\_PARAM2.

OrderNo [in]

Request number. Specify any number (range: 1 to 65535).

When 65535 (0xFFFF) is specified, RefId becomes valid.

FrameNum [in]

Number of the image. Specify the number of the image included in the order (range: 1 to 9999).

PaperWidth [in]

Paper width. Specify the paper width to be printed (unit: 1/10 mm).

PaperLengthC [in]

PaperLengthP [in]

PaperLengthH [in]

Paper advance length (height) (unit: 1/10 mm)

Specify the advance length/height of the paper to be printed.

You can check the available range with QssGetPaperAD(). In case of printing on the sheet paper, specify the value of QSS\_PAPER\_INFO\_AD::PaperLengthMin of QssGetPaperAD ().

Surface [in]

Paper surface. Specify the paper surface to be printed (range: 1 to 4).

WithBorderC [in]

WithBorderP [in]

WithBorderH [in]

Border width. Specify the border width of the print (range: 0 to 99, unit: 1/10 mm).

In case of printing with border on the sheet paper, specify the borderless paper. If the borderless paper is not specified, the border width specified will not appear correctly.

IndexPrintFlg [in]

Unused

PaperFittingFlg [in]

Paper fitting. Specify the size of the image to be printed.

QSS_PF_CUT	Cut Adjust the image size so it does not generate any white border on the page. A part of image may not be printed.
QSS_PF_WHOLE	Whole Adjust the image size so the whole image is printed on the page. White border may appear on the page.
QSS_PF_SAME	Real size Images are printed with actual image data size.

IndexPaperWidth [in]

Unused

IndexSurface [in]

Unused

CmsFlg [in]

Color matching. Specify whether color matching will be applied. When color matching is performed with the application, specify QSS\_CMS\_OFF.

QSS_CMS_ON	Color matching will be performed.
QSS_CMS_OFF	Color matching will not be performed.

Reserve1

Unused

RefId [in]

Reference number. Specify any number. When the number exceeds 65535, RefId is used (unit: 1 to 999999999999999999).

SorterNum

Unused

PaperName [in]

Paper name (32 byte)

The string is NULL terminated. In case of printing on the sheet paper, specify the paper name of the paper information (QSS\_PAPER\_INFO\_AD). In case of printing on the roll paper, specify NULL.

BothSidePrint [in]

Duplex printing. Specify whether duplex printing will be performed.

QSS_TRUE	Duplex printing will be performed. When the printer does not support duplex printing, error QSS_NOT_SUPPORT_BOTHSIDEPRINT will be returned.
QSS_FALSE	Duplex printing will not be performed.
Other それ以外	Duplex printing will not be performed.

Copies [in]



Number of copies. Specify the number of copies (range: 1 to 9999).  
 When the number of copies is specified, the number of copies specified for each image (QSS\_FRAME\_PARAM\_AD::RepeatNum of QssTransmitFile()) will be ignored. When 0 is set, the number of copies specified for each image will be used.  
 When duplex printing is to be performed (i.e. QSS\_ORDER\_PARAM\_AD::BothSidePrint is set to QSS\_TRUE), or collation is to be performed (QSS\_ORDER\_PARAM\_AD::Collate is set to QSS\_TRUE), this variable must be set.

Collate [in]

Specify whether to collate prints.

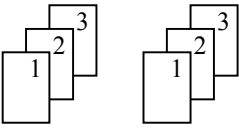
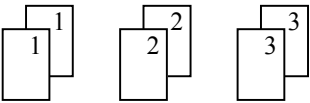
QSS_TRUE	When multiple copies of photobook or multiple sets of photos are printed, they will be collated as shown in the figure below. 
QSS_FALSE	No collation 
Others	No collation.

FastPrintFlg [in]

Fast print flag. Specify whether to perform fast print.

QSS_FAST_PRINT_OFF	Fast print function will not be used.
QSS_FAST_PRINT_ON	Fast print function will be used.

Resolut [in]

Specify the resolution of paper to use for printing (unit: 1/10 dpi). When 0 is set in this variable, the default resolution of the paper will be used.

PaperTone [in]

Gradation

Color depth for a pixel is specified to represent the gradation of paper. In case QSS\_PAPER\_TONE\_NONE is set, gradation specified on the printer will be used.

QSS_PAPER_TONE_NONE	Not specify
QSS_PAPER_TONE_24	24 bpp
QSS_PAPER_TONE_36	36 bpp
QSS_PAPER_TONE_48	48 bpp

PaperLengthMin [in]

PaperLengthMax [in]

Specify the minimum and maximum paper advance lengths to be applied to the order (unit: 1/10 mm). This variable will be used by EZ Controller to determine which printer will be used for printing the order when multiple printers are connected to EZ Controller.

“QSS\_INVALID\_PARAMETER” will return in the following cases:

- When 0 is set to this variable
- When this variable is inconsistent with QSS\_FRAME\_PARAM\_AD::PaperLength
- When the PaperLengthMinC value is bigger than the PaperLengthMaxC value.

PaperWidthB [in]

Specify the width of the paper to use for printing. (unit: 1/10 mm)

PaperSurfaceB [in]

Specify the surface type of the paper to use for printing. (range: 1-4)

PaperNameB [in]

Specify the paper name (32 byte).

The string must be NULL terminated. To print on sheet paper, specify the paper name in the paper information (QSS\_PAPER\_INFO\_AD). To print on roll paper, set NULL.

ResolutB [in]

Specify the resolution of paper to use for printing (unit: 1/10 dpi). When 0 is set in this variable, the default resolution of the paper will be used.

PaperToneB [in]

Gradation

Color depth for a pixel is specified to represent the gradation of paper.

In case QSS\_PAPER\_TONE\_NONE is set, gradation specified on the printer will be used.

QSS_PAPER_TONE_NONE	Not specify
QSS_PAPER_TONE_24	24 bpp
QSS_PAPER_TONE_36	36 bpp
QSS_PAPER_TONE_48	48 bpp

PaperLengthMinB [in]

PaperLengthMaxB [in]

Specify the minimum and maximum paper advance lengths to be applied to the order (unit: 1/10 mm). This variable will be used by EZ Controller to determine which printer will be used for printing the order when multiple printers are connected to EZ Controller.

“QSS\_INVALID\_PARAMETER” will return in the following cases:

- When 0 is set to this variable
- When this variable is inconsistent with QSS\_FRAME\_PARAM\_AD ::PaperLength
- When the PaperLengthMinC value is bigger than the PaperLengthMaxC value.

PaperWidthC [in]

Specify the width of the paper to use for printing. (unit: 1/10 mm)

PaperSurfaceC [in]

Specify the surface type of the paper to use for printing. (range: 1-4)

PaperNameC [in]

Specify the paper name (32 byte).

The string must be NULL terminated. To print on sheet paper, specify the paper name in the paper information (QSS\_PAPER\_INFO\_AD). To print on roll paper, set NULL.

ResolutC [in]

Specify the resolution of paper to use for printing (unit: 1/10 dpi). When 0 is set in this variable, the default resolution of the paper will be used.

PaperToneC [in]

Gradation

Color depth for a pixel is specified to represent the gradation of paper.

In case QSS\_PAPER\_TONE\_NONE is specified, gradation specified on the printer will be used.

QSS_PAPER_TONE_NONE	Not specify
QSS_PAPER_TONE_24	24 bpp
QSS_PAPER_TONE_36	36 bpp
QSS_PAPER_TONE_48	48 bpp

PaperLengthMinC [in]

PaperLengthMaxC [in]

Specify the minimum and maximum paper advance lengths to be applied to the order (unit: 1/10 mm). This variable will be used by EZ Controller to determine which printer will be used for printing the order when multiple printers are connected to EZ Controller.

“QSS\_INVALID\_PARAMETER” will return in the following cases:

- When 0 is set to this variable
- When this variable is inconsistent with QSS\_FRAME\_PARAM\_AD ::PaperLength
- When the PaperLengthMinC value is bigger than the PaperLengthMaxC value.

PaperWidthD [in]

Specify the width of the paper to use for printing. (unit: 1/10 mm)

PaperSurfaceD [in]

Specify the surface type of the paper to use for printing. (range: 1-4)

PaperNameD [in]

Specify the paper name (32 byte).

The string must be NULL terminated. To print on sheet paper, specify the paper name in the paper information (QSS\_PAPER\_INFO\_AD). To print on roll paper, set NULL.

ResolutD [in]

Specify the resolution of paper to use for printing (unit: 1/10 dpi). When 0 is set in this variable, the default resolution of the paper will be used.

PaperToneD [in]

Gradation

Color depth for a pixel is specified to represent the gradation of paper.

In case QSS\_PAPER\_TONE\_NONE is specified, gradation specified on the printer will be used.

QSS_PAPER_TONE_NONE	Not specify
QSS_PAPER_TONE_24	24 bpp
QSS_PAPER_TONE_36	36 bpp
QSS_PAPER_TONE_48	48 bpp

PaperLengthMinD [in]

PaperLengthMaxD [in]

Specify the minimum and maximum paper advance lengths to be applied to the order (unit: 1/10 mm). This variable will be used by EZ Controller to determine which printer will be used for printing the order when multiple printers are connected to EZ Controller.

“QSS\_INVALID\_PARAMETER” will return in the following cases:

- When 0 is set to this variable
- When this variable is inconsistent with QSS\_FRAME\_PARAM\_AD::PaperLength
- When the PaperLengthMinC value is bigger than the PaperLengthMaxC value.

IndexPrintNum [in]

Unused.

EnablePriority [in]

Order priority flag that specifies whether or not to enable order priority

(QSS\_ORDER\_PARAM\_AD::Priority). Set 0 to disable it, and 1 to enable it.

Priority [in]

Specify the priority of order. (range: 0-65535)

This variable is only available with NetOrder ver 3.0.0 and up. With the earlier versions of NetOrder, this variable will be ignored and “QSS\_PRIORITY\_NORMAL” will always be applied. To use this variable, set a value bigger than 0x03000000 to QSS\_CLIENT\_INFO::Version (version of client information), and set “1” to QSS\_ORDER\_PARAM\_AD::EnablePriority (order priority flag). When QSS\_ORDER\_PARAM\_AD::EnablePriority is not set to 1, this variable will be ignored.

QSS_PRIORITY_HIGHEST	0-99	Highest priority
QSS_PRIORITY_HIGH	100-199	High priority
QSS_PRIORITY_NORMAL	200-299	Normal
QSS_PRIORITY_LOW	300-65534	Low priority
QSS_PRIORITY_NONE	65535	No priority specified

PrintMode [in]

Specify the printing method.

QSS_PRINT_MODE_AUTO	AUTO
QSS_PRINT_MODE_PJP	PJP
QSS_PRINT_MODE_PPI	PPI

Wait [in]

Order hold flag. Specify whether or not to hold the order received.

QSS_WAIT_OFF	When an order is received, set the status of the order to “waiting to be printed”. (Start printing as soon as the printer is ready.)
QSS_WAIT_ON	When an order is received, set the status of the order to “wait (hold)”.

BlankPageNum [in]

Specify the number of blank pages to be inserted to the order when performing duplex printing.  
(range: 0-9999)

This variable must be set to insert a blank page for duplex printing by using the fast print function.

Reserve  
Unused

**7.5. QssGetPrinterInfo**

Refer to NetOrder 2.3.0 API Reference.

**7.6. QssGetPaperAD**

```
long QssGetPaperAD (
    short    Flag,
    long     BufferNum,
    long     *PaperNum,
    QSS_PAPER_INFO_AD * PaperInfo);
```

Flag [in]

Get flag. Specify the information to get.

0	Get the information of the paper that is installed on the printer.
1	Get the information of all the available paper.

BufferNum [in]

Number of paper information to store. Specify the number of paper information (QSS\_PAPER\_INFO\_AD) to be stored in PaperInfo.

PaperNum [out]

Return the number of the paper information.

PaperInfo [out]

Area where the paper information is stored

**7.6.1. Command for TCP/IP**

Request	2100H	<table border="1"> <tr> <td>TQssMsg</td> <td>Flag</td> <td></td> <td></td> <td></td> <td></td> </tr> <tr> <td>16</td> <td>2</td> <td></td> <td></td> <td></td> <td></td> </tr> </table>					TQssMsg	Flag					16	2				
TQssMsg	Flag																	
16	2																	
Response	2101H	<table border="1"> <tr> <td>TQssMsg</td> <td>WSQSS_RESULT</td> <td>TotalCount</td> <td>SequenceNo</td> <td>WSQSS_PAPER_INFO_AD</td> <td></td> </tr> <tr> <td>16</td> <td>32</td> <td>4</td> <td>4</td> <td>100</td> <td></td> </tr> </table>					TQssMsg	WSQSS_RESULT	TotalCount	SequenceNo	WSQSS_PAPER_INFO_AD		16	32	4	4	100	
TQssMsg	WSQSS_RESULT	TotalCount	SequenceNo	WSQSS_PAPER_INFO_AD														
16	32	4	4	100														

--	--	--	--	--	--

TQssMsg [in]

Set the header information (TQssMsg).

Flag [in]

Get flag. Specify the information to get.

0	Get the information of the paper that is installed on the printer.
1	Get the information of all the available paper.

WSQSS\_RESULT [out]

Return the result (WSQSS\_RESULT).

TotalCount [out]

Return the number of the paper information.  
 SequenceNo [out]  
 Response number. The number of the response matches that of the paper information.  
 WSQSS\_PAPER\_INFO\_AD [out]  
 Paper information

**7.6.2. Return Value**

Return QSS\_SUCCESS when succeeded, else return QSS\_FAIL. When there exists paper information that is not gotten, return QSS\_REMAINING\_DATA.

**7.6.3. Description**

Get the information of the paper that is installed on the printer or the available paper with the get flag. When 0 is specified in BufferNum, return PaperNum that the number of paper information is set. The usage is basically the same as that of QssGetPaper().

**7.7. QssTransmitFileAD**

```
long QssTransmitFileAD(
    QSS_CLIENT_INFO ClientInfo,
    QSS_FRAME_PIPE Pipe,
    QSS_FRAME_PARAM_AD FrameParam);
```

ClientInfo  
 Set the caller Client information (QSS\_CLIENT\_INFO).

Pipe  
 Set the RPC pipe information (QSS\_FRAME\_PIPE).

FrameParam  
 Set the frame information (QSS\_FRAME\_PARAM\_AD).

**7.7.1. Command Format for TCP/IP**

Request	2200H	<table border="1"> <tr> <td>TQssMsg</td> <td>WSQSS_CLIENT_INFO</td> <td>WSQSS_FRAME_PARAM_AD</td> <td>Image data</td> </tr> <tr> <td>16</td> <td>96</td> <td>480</td> <td>Variable</td> </tr> </table>				TQssMsg	WSQSS_CLIENT_INFO	WSQSS_FRAME_PARAM_AD	Image data	16	96	480	Variable
		TQssMsg	WSQSS_CLIENT_INFO	WSQSS_FRAME_PARAM_AD	Image data								
16	96	480	Variable										
Response	2201H	<table border="1"> <tr> <td>TQssMsg</td> <td>WSQSS_RESULT</td> </tr> <tr> <td>16</td> <td>32</td> </tr> </table>				TQssMsg	WSQSS_RESULT	16	32				
TQssMsg	WSQSS_RESULT												
16	32												

--	--	--

TQssMsg [in]  
 Set the header information (TQssMsg).  
 WSQSS\_CLIENT\_INFO [in]  
 Set the Client information (WSQSS\_CLIENT\_INFO).  
 WSQSS\_FRAME\_PARAM\_AD [in]  
 Set the frame information (WSQSS\_FRAME\_PARAM\_AD).  
 WSQSS\_RESULT [out]

Return the result (WSQSS\_RESULT).

**7.7.2. Return Value**

Return QSS\_SUCCESS when succeeded, else return either of the following:

QSS_INVALID_ORDERNO	Request number is out of the range or has been already used.
QSS_INVALID_FRAMENO	Invalid frame number
QSS_NOT_SUPPORT_FORMAT	Image format not supported
QSS_INVALID_REPEATNUM	Invalid repeat number
QSS_INVALID_PAPER	Invalid paper When the specified paper is not found, QSS_INVALID_PAPER will be returned, too.
QSS_INVALID_PAPERFITTING	Invalid paper fitting
QSS_INVALID_PAPERLENGTH	Invalid paper length
QSS_RECEIVE_ABORT	Order rejected or print cancelled

**7.8. QssSetOrderAD**

```
long QssSetOrderAD (
    QSS_CLIENT_INFO ClientInfo,
    QSS_ORDER_PARAM_AD OrderParam);
```

ClientInfo [in]  
Set the caller Client information (QSS\_CLIENT\_INFO).

OrderParam [in]  
Set the order information (QSS\_ORDER\_PARAM\_AD).

**7.8.1. Command format for TCP/IP**

Request	2300H	<table border="1"> <tr> <td>TQssMsg</td> <td>WSQSS_CLIENT_INFO</td> <td colspan="2">WSQSS_ORDER_PARAM_AD</td> </tr> <tr> <td>16</td> <td>96</td> <td colspan="2">240</td> </tr> </table>			TQssMsg	WSQSS_CLIENT_INFO	WSQSS_ORDER_PARAM_AD		16	96	240	
		TQssMsg	WSQSS_CLIENT_INFO	WSQSS_ORDER_PARAM_AD								
16	96	240										
Response	2301H	<table border="1"> <tr> <td>TQssMsg</td> <td>WSQSS_RESULT</td> </tr> <tr> <td>16</td> <td>32</td> </tr> </table>			TQssMsg	WSQSS_RESULT	16	32				
TQssMsg	WSQSS_RESULT											
16	32											

--	--	--

- TQssMsg [in]  
Set the header information (TQssMsg).
- WSQSS\_CLIENT\_INFO [in]  
Set the Client information (WSQSS\_CLIENT\_INFO).
- WSQSS\_ORDER\_PARAM\_AD [in]  
Set the order information (QSS\_ORDER\_PARAM\_AD).
- WSQSS\_RESULT [out]  
Return the result (WSQSS\_RESULT).

**7.8.2. Return Value**

Return QSS\_SUCCESS when succeeded, else return either of the following:

QSS_INVALID_ORDERNO	Request number is out of the range or has been already used.
QSS_INVALID_PAPER	Invalid paper When the specified paper is not found, QSS_INVALID_PAPER will be returned, too.
QSS_INVALID_FRAMENUM	Invalid frame number
QSS_INVALID_WBSIZE	Invalid white border width
QSS_INVALID_INDEXSIZE	Invalid index format
QSS_INVALID_PAPERFITTING	Invalid paper fitting
QSS_INVALID_PAPERLENGTH	Invalid paper advance length
QSS_RECEIVE_ABORT	Order rejected or print cancelled
QSS_NOT_SUPPORT_BOTHSIDEPRINT	Printer does not support duplex printing
QSS_INVALID_COPIES	Invalid number of copies
QSS_INVALID_BLANKPAGENUM	Invalid number of blank pages

**7.8.3. Description**

This API completes the order spool, and then the order is in print queue. The usage is basically the same as that of QssSetOrder().

**7.9. QssSetBlankPageAD**

```
long QssSetBlankPageAD (
    QSS_CLIENT_INFO ClientInfo,
    unsigned short OrderNo,
    unsigned hyper RefId);
```

ClientInfo [in]

Set the caller Client information (QSS\_CLIENT\_INFO).

OrderNo [in]

Request number. Specify any number (range: 1 to 65535).  
When 65535 (0xFFFF) is specified, RefId becomes valid.

RefId [in]

Reference number. Specify any number. When the number exceeds 65535, RefId is used (unit: 1 to 999999999999999999).

**7.9.1. Command for TCP/IP**

Request	2400H	<table border="1"> <tr> <td>TQssMsg</td> <td>WSQSS_CLIENT_INFO</td> <td>OrderNo</td> <td>RefId</td> </tr> <tr> <td>16</td> <td>96</td> <td>2</td> <td>8</td> </tr> </table>				TQssMsg	WSQSS_CLIENT_INFO	OrderNo	RefId	16	96	2	8
		TQssMsg	WSQSS_CLIENT_INFO	OrderNo	RefId								
16	96	2	8										
Response	2401H	<table border="1"> <tr> <td>TQssMsg</td> <td>WSQSS_RESULT</td> </tr> <tr> <td>16</td> <td>32</td> </tr> </table>		TQssMsg	WSQSS_RESULT	16	32						
		TQssMsg	WSQSS_RESULT										
16	32												

--	--	--

TQssMsg [in]  
 Header information  
 WSQSS\_CLIENT\_INFO [in]  
 Set the Client information (WSQSS\_CLIENT\_INFO).  
 OrderNo [in]  
 Set the request number.  
 RefId [in]  
 Set the reference number.  
 WSSQSS\_RESULT [out]  
 Return the result (WSQSS\_RESULT).

**7.9.2. Return Value**

Return QSS\_SUCCESS when succeeded, else return either of the following:

QSS_INVALID_ORDERNO	Request number is out of the range.
---------------------	-------------------------------------

**7.9.3. Description**

This API inserts a blank page in the location called. When the fast print function is not to be used, call this API before calling QssSetOrderAD().

To use the fast print function, call this API as many times as the number of blank pages specified in order information (QSS\_ORDER\_PARAM\_AD::BlankPageNum) of QssSetOrderAD().

When duplex printing is not specified, this API will be ignored.

For instance, if you want to make the 3<sup>rd</sup> page blank, call this API after QssTrasmitFile() of the 2<sup>nd</sup> frame is called as shown in the sequence below.

- When the fast print function is not used:



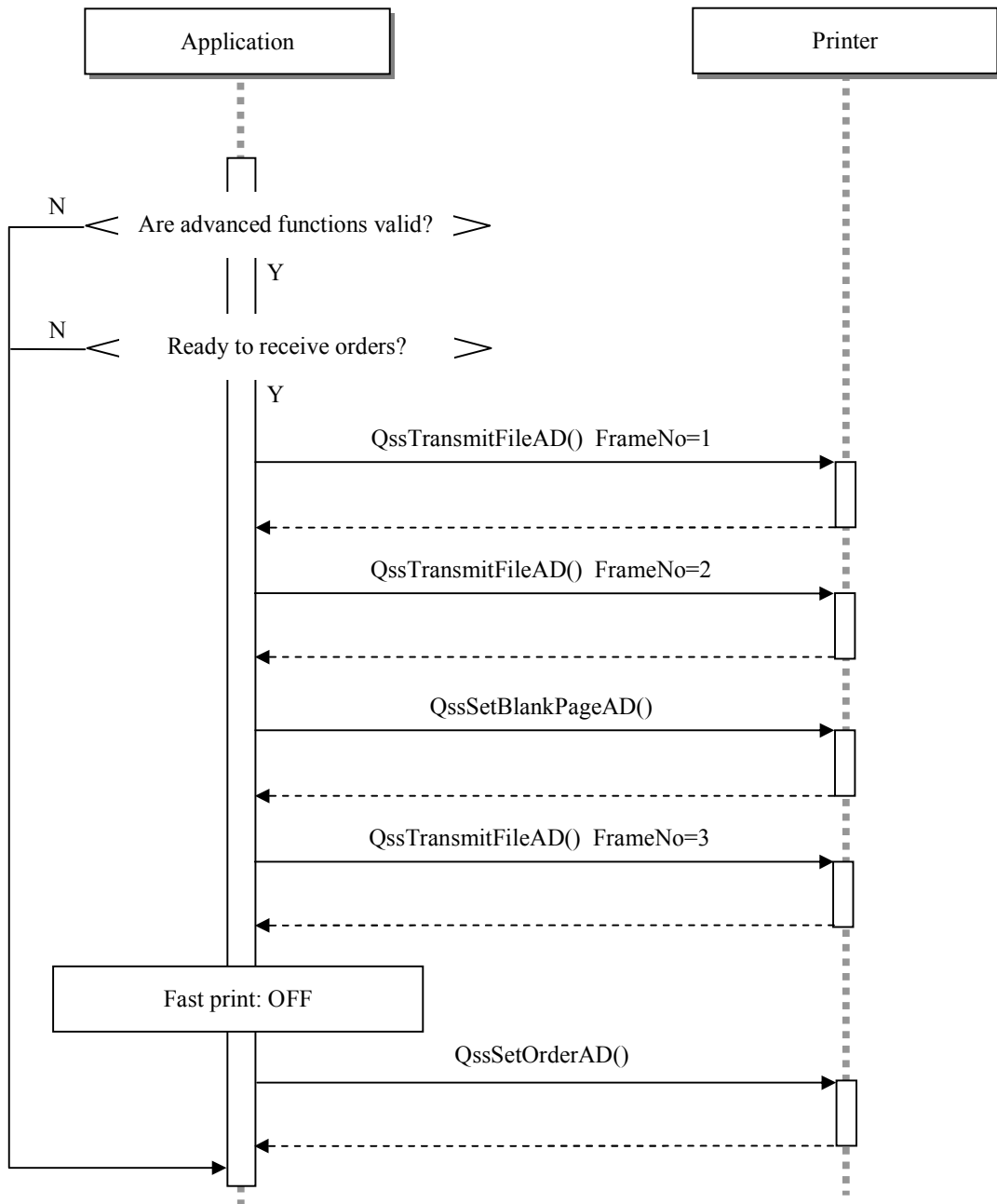



## 8. Note for Using the Advanced Functions

### 8.1. Printing on the Sheet Paper

- ◆ In case of printing on the sheet paper, specify the paper name of the sheet paper to be used in PaperName when the order is sent with QssSetOrderAD (), which specifies which type of paper (glossy, semi-glossy, etc) to use for printing.
- ◆ When you make the print image of the real size with the application, calculate the print image size so it matches the print area. The print area will differ depending on the paper type or the presence of white border. Cropping amount is specified with positive value for borderless paper and with negative value for paper with border.

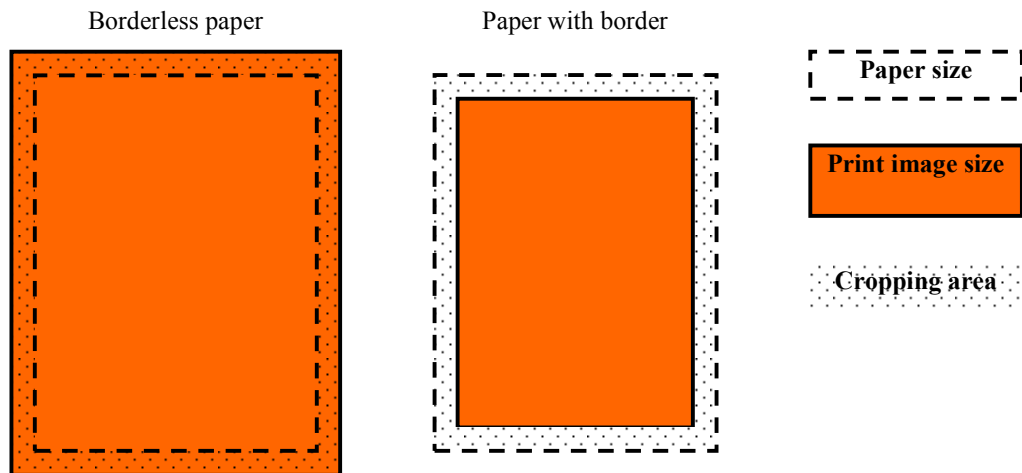

How to calculate the print image size

Cropping area (top) (pixel) = TrimTop / 254 \* Resolut  
 Cropping area (bottom) (pixel) = TrimBottom / 254\* Resolut  
 Cropping area (left) (pixel) = TrimLeft / 254\* Resolut  
 Cropping area (right) (pixel) = TrimRight / 254\* Resolut

Print image size (width) (pixel)  
 = PaperWidht / 254\* Resolut + cropping area (left) + cropping area (right)

Print image size (height) (pixel)  
 = PaperLenghtMin / 254 \* Resolut + cropping area (top) + cropping area (bottom)

- ◆ In order to make a print with border, specify the borderless paper and specify the border width in QSS\_ORDER\_PARAM\_AD::WithBorderC.

### 8.2. Duplex Printing

- ◆ You can check whether the printer supports duplex printing with EnableBothSidePrint of QSS\_PRINTER\_INFO:: of QssGetName().
- ◆ In order to perform duplex printing, specify QSS\_TRUE in QSS\_ORDER\_PARAM\_AD:: BothSidePrint and the number of copies in QSS\_ORDER\_PARAM\_AD::Copies when the order information is sent with QssSetOrderAD ().
- ◆ In order to collate, specify QSS\_TRUE in QSS\_ORDER\_PARAM\_AD:: Collate.
- ◆ Odd page will be printed on the front and even page on back.
- ◆ Application will print the binding margin and page number.

- ◆ Print size cannot be specified per image with duplex printing. One print size will be applied for each order.
- ◆ When index print is specified with duplex printing, the index will be made with single-side print and printed at the end of the order. For instance, when the number of copies is two, the index will be printed after the 2<sup>nd</sup> pages are printed.
- ◆ As the dry minilab that supports duplex printing does not have the CVP unit, CVP will be invalid.

### 8.3. Changing resolution

- ◆ In order to switch printing resolution, set the QSS\_PAPER\_INFO\_AD::Resolut value (default printing resolution specified in paper information) that can be obtained via QssGetPaperAD() to the following paper resolution of the frame information of QssTransmitFileAD() or order information of QssSetOrderAD().
  - QSS\_FRAME\_PARAM\_AD::Resolut
  - QSS\_FRAME\_PARAM\_AD::ResolutB
  - QSS\_FRAME\_PARAM\_AD::ResolutC
  - QSS\_FRAME\_PARAM\_AD::ResolutD
  - QSS\_ORDER\_PARAM\_AD::Resolut
- ◆ In order to change gradation of print, set a bit value of QSS\_PAPER\_INFO\_AD::PaperTone (paper gradation specified in paper information) that can be obtained via QssGetPaperAD() to the following paper gradation of the frame information of QssTransmitFileAD() or order information of QssSetOrderAD().
  - QSS\_FRAME\_PARAM\_AD::PaperTone
  - QSS\_FRAME\_PARAM\_AD::PaperToneB
  - QSS\_FRAME\_PARAM\_AD::PaperToneC
  - QSS\_FRAME\_PARAM\_AD::PaperToneD
  - QSS\_ORDER\_PARAM\_AD::PaperTone

## 9. Note for Using the Fast Print Function

### 9.1. When not using the fast print function

- ◆ In order not to use the fast print function, set QSS\_FAST\_PRINT\_OFF to QSS\_ORDER\_PARAM\_AD::FastPrintFlg.
- ◆ In order not to use the fast print function, call QssTransmitFileAD() and QssSetOrderAD() as described below. Refer to “7. Sequence” for sequence.
  - (1) Call QssTransmitFileAD() as many as number of images.
  - (2) Call QssSetOrderAD().
- ◆ The following variables of QSS\_ORDER\_PARAM\_AD will be ignored.
  - QSS\_ORDER\_PARAM\_AD::PaperWidthB
  - QSS\_ORDER\_PARAM\_AD::PaperSurfaceB
  - QSS\_ORDER\_PARAM\_AD::PaperNameB
  - QSS\_ORDER\_PARAM\_AD::ResolutB
  - QSS\_ORDER\_PARAM\_AD::PaperToneB
  - QSS\_ORDER\_PARAM\_AD::PaperLengthMinB
  - QSS\_ORDER\_PARAM\_AD::PaperLengthMaxB
  - QSS\_ORDER\_PARAM\_AD::PaperWidthC
  - QSS\_ORDER\_PARAM\_AD::PaperSurfaceC
  - QSS\_ORDER\_PARAM\_AD::PaperNameC
  - QSS\_ORDER\_PARAM\_AD::ResolutC
  - QSS\_ORDER\_PARAM\_AD::PaperToneC
  - QSS\_ORDER\_PARAM\_AD::PaperLengthMinC
  - QSS\_ORDER\_PARAM\_AD::PaperLengthMaxC
  - QSS\_ORDER\_PARAM\_AD::PaperWidthD
  - QSS\_ORDER\_PARAM\_AD::PaperSurfaceD
  - QSS\_ORDER\_PARAM\_AD::PaperNameD

- QSS\_ORDER\_PARAM\_AD::ResolutD
- QSS\_ORDER\_PARAM\_AD::PaperToneD
- QSS\_ORDER\_PARAM\_AD::PaperLengthMinD
- QSS\_ORDER\_PARAM\_AD::PaperLengthMaxD

## 9.2. When using the fast print function

- ◆ In order to use the fast print function, set QSS\_FAST\_PRINT\_ON to QSS\_ORDER\_PARAM\_AD::FastPrintFlg.
- ◆ In order to use the fast print function, call QssTransmitFileAD() and QssSetOrderAD() as described below. Refer to “7. Sequence” for sequence.
  - (1) Call QssSetOrderAD().
  - (2) Call QssTransmitFileAD() as many as number of images.
- ◆ When using 1 type of paper for printing of an order, set the paper information necessary for printing to the following variables in QSS\_ORDER\_PARAM\_AD:
  - QSS\_ORDER\_PARAM\_AD::PaperWidth
  - QSS\_ORDER\_PARAM\_AD::PaperSurface
  - QSS\_ORDER\_PARAM\_AD::PaperName
  - QSS\_ORDER\_PARAM\_AD::Resolut
  - QSS\_ORDER\_PARAM\_AD::PaperTone
  - QSS\_ORDER\_PARAM\_AD::PaperLengthMin
  - QSS\_ORDER\_PARAM\_AD::PaperLengthMax
- ◆ When using 2 different types of paper for printing of an order, set the paper information necessary for printing to the following variables in QSS\_ORDER\_PARAM\_AD:
  - QSS\_ORDER\_PARAM\_AD::PaperWidth
  - QSS\_ORDER\_PARAM\_AD::PaperSurface
  - QSS\_ORDER\_PARAM\_AD::PaperName
  - QSS\_ORDER\_PARAM\_AD::Resolut
  - QSS\_ORDER\_PARAM\_AD::PaperTone
  - QSS\_ORDER\_PARAM\_AD::PaperLengthMin
  - QSS\_ORDER\_PARAM\_AD::PaperLengthMax
  - QSS\_ORDER\_PARAM\_AD::PaperWidthB
  - QSS\_ORDER\_PARAM\_AD::PaperSurfaceB
  - QSS\_ORDER\_PARAM\_AD::PaperNameB
  - QSS\_ORDER\_PARAM\_AD::ResolutB
  - QSS\_ORDER\_PARAM\_AD::PaperToneB
  - QSS\_ORDER\_PARAM\_AD::PaperLengthMinB
  - QSS\_ORDER\_PARAM\_AD::PaperLengthMaxB
- ◆ When using 3 different types of paper for printing of an order, set the paper information necessary for printing to the following variables in QSS\_ORDER\_PARAM\_AD:
  - QSS\_ORDER\_PARAM\_AD::PaperWidth
  - QSS\_ORDER\_PARAM\_AD::PaperSurface
  - QSS\_ORDER\_PARAM\_AD::PaperName
  - QSS\_ORDER\_PARAM\_AD::Resolut
  - QSS\_ORDER\_PARAM\_AD::PaperTone
  - QSS\_ORDER\_PARAM\_AD::PaperLengthMin
  - QSS\_ORDER\_PARAM\_AD::PaperLengthMax
  - QSS\_ORDER\_PARAM\_AD::PaperWidthB
  - QSS\_ORDER\_PARAM\_AD::PaperSurfaceB
  - QSS\_ORDER\_PARAM\_AD::PaperNameB
  - QSS\_ORDER\_PARAM\_AD::ResolutB
  - QSS\_ORDER\_PARAM\_AD::PaperToneB
  - QSS\_ORDER\_PARAM\_AD::PaperLengthMinB
  - QSS\_ORDER\_PARAM\_AD::PaperLengthMaxB
  - QSS\_ORDER\_PARAM\_AD::PaperWidthC
  - QSS\_ORDER\_PARAM\_AD::PaperSurfaceC
  - QSS\_ORDER\_PARAM\_AD::PaperNameC

- QSS\_ORDER\_PARAM\_AD::ResolutC
- QSS\_ORDER\_PARAM\_AD::PaperToneC
- QSS\_ORDER\_PARAM\_AD::PaperLengthMinC
- QSS\_ORDER\_PARAM\_AD::PaperLengthMaxC
- ◆ When using 4 different types of paper for printing of an order, set the paper information necessary for printing to the following variables in QSS\_ORDER\_PARAM\_AD:
  - QSS\_ORDER\_PARAM\_AD::PaperWidth
  - QSS\_ORDER\_PARAM\_AD::PaperSurface
  - QSS\_ORDER\_PARAM\_AD::PaperName
  - QSS\_ORDER\_PARAM\_AD::Resolut
  - QSS\_ORDER\_PARAM\_AD::PaperTone
  - QSS\_ORDER\_PARAM\_AD::PaperLengthMin
  - QSS\_ORDER\_PARAM\_AD::PaperLengthMax
  - QSS\_ORDER\_PARAM\_AD::PaperWidthB
  - QSS\_ORDER\_PARAM\_AD::PaperSurfaceB
  - QSS\_ORDER\_PARAM\_AD::PaperNameB
  - QSS\_ORDER\_PARAM\_AD::ResolutB
  - QSS\_ORDER\_PARAM\_AD::PaperToneB
  - QSS\_ORDER\_PARAM\_AD::PaperLengthMinB
  - QSS\_ORDER\_PARAM\_AD::PaperLengthMaxB
  - QSS\_ORDER\_PARAM\_AD::PaperWidthC
  - QSS\_ORDER\_PARAM\_AD::PaperSurfaceC
  - QSS\_ORDER\_PARAM\_AD::PaperNameC
  - QSS\_ORDER\_PARAM\_AD::ResolutC
  - QSS\_ORDER\_PARAM\_AD::PaperToneC
  - QSS\_ORDER\_PARAM\_AD::PaperLengthMinC
  - QSS\_ORDER\_PARAM\_AD::PaperLengthMaxC
  - QSS\_ORDER\_PARAM\_AD::PaperWidthD
  - QSS\_ORDER\_PARAM\_AD::PaperSurfaceD
  - QSS\_ORDER\_PARAM\_AD::PaperNameD
  - QSS\_ORDER\_PARAM\_AD::ResolutD
  - QSS\_ORDER\_PARAM\_AD::PaperToneD
  - QSS\_ORDER\_PARAM\_AD::PaperLengthMinD
  - QSS\_ORDER\_PARAM\_AD::PaperLengthMaxD